

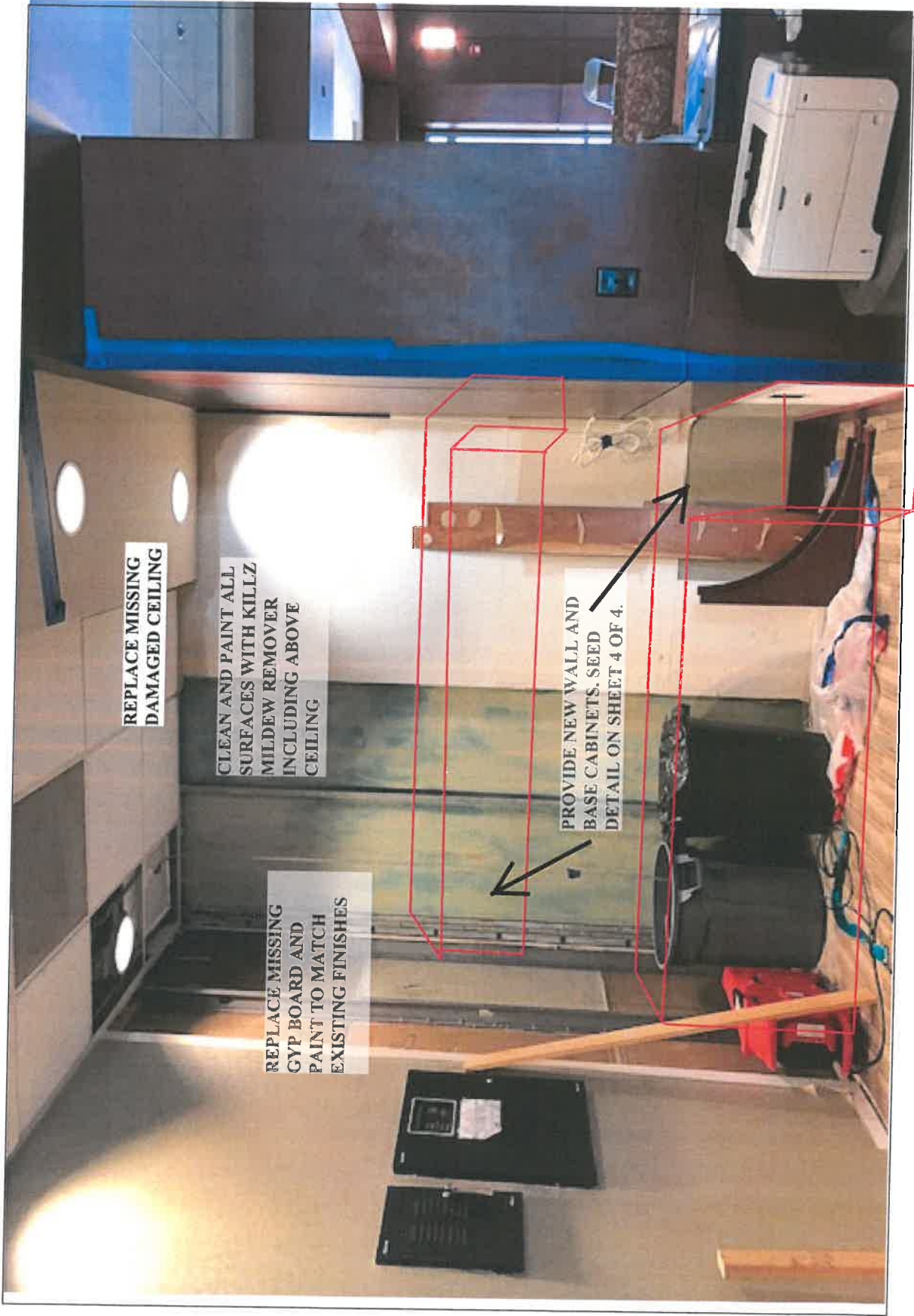

PICTURE # 1

AREA 1 - HARGRAY BUILDING RECEPTION AREA



REPLACE MISSING
DAMAGED CEILING

CLEAN AND PAINT ALL
SURFACES WITH KILLZ
MILDEW REMOVER
INCLUDING ABOVE
CEILING

PROVIDE NEW WALL AND
BASE CABINETS, SEED
DETAIL ON SHEET 4 OF 4.

REPLACE MISSING
GYP BOARD AND
PAINT TO MATCH
EXISTING FINISHES

PICTURE # 1a



PICTURE # 1c



PICTURE # 1b

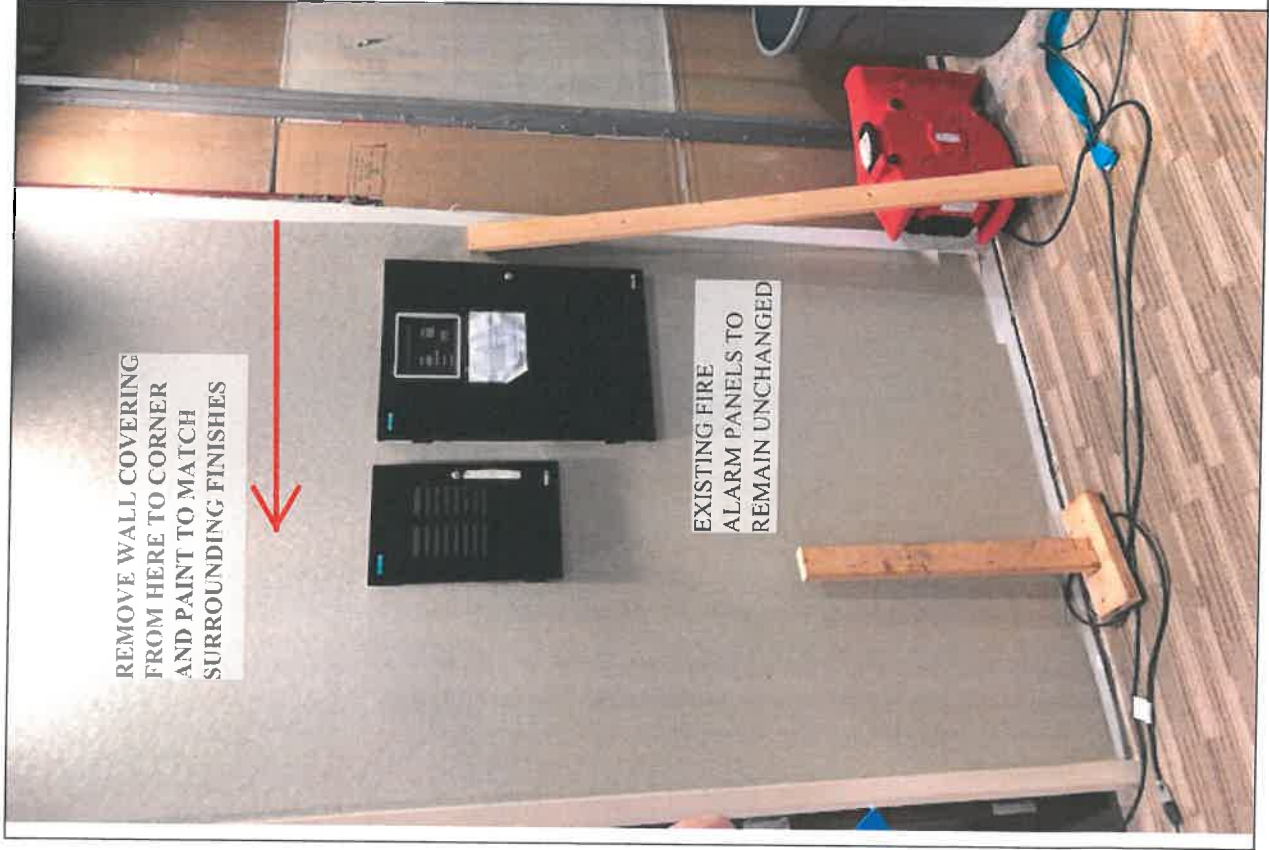

PICTURE # 1d

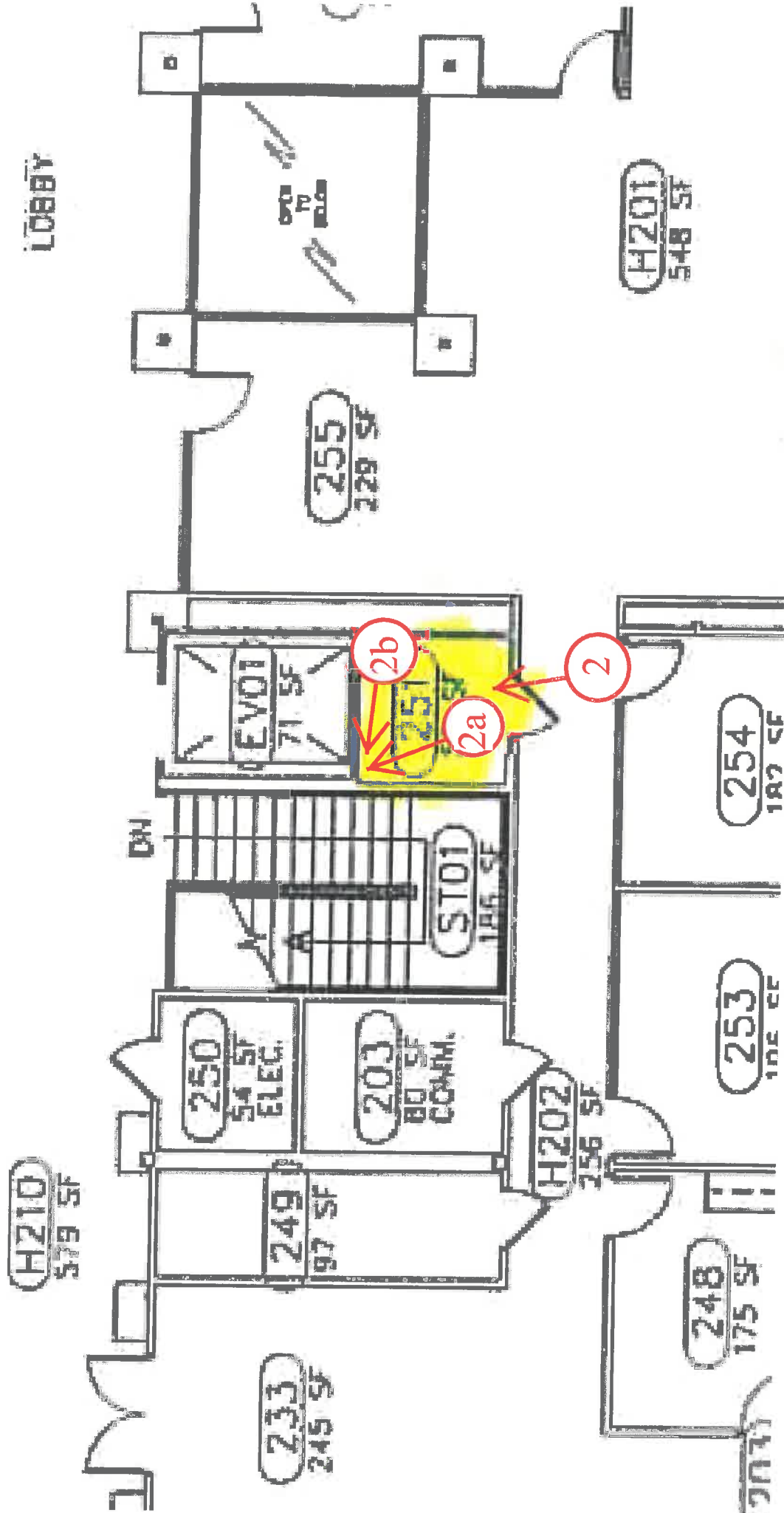

AREA 2
 PICTURE LOCATOR
 PLAN



PICTURE # 2

AREA - 2 STORAGE ROOM 251



PICTURE # 2a

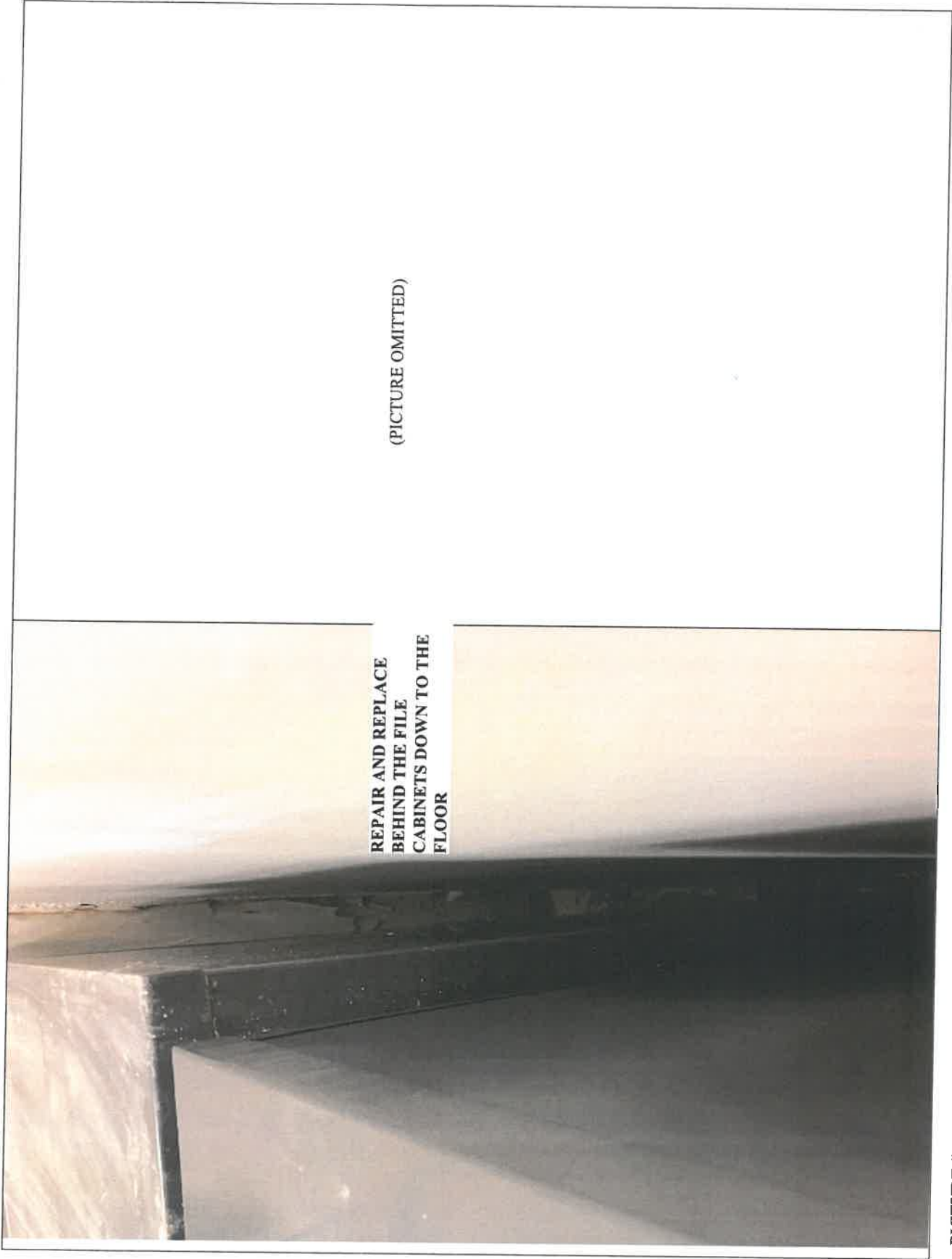

REPAIR AND REPLACE
BEHIND THE FILE
CABINETS DOWN TO THE
FLOOR

(PICTURE OMITTED)

PICTURE # 2b

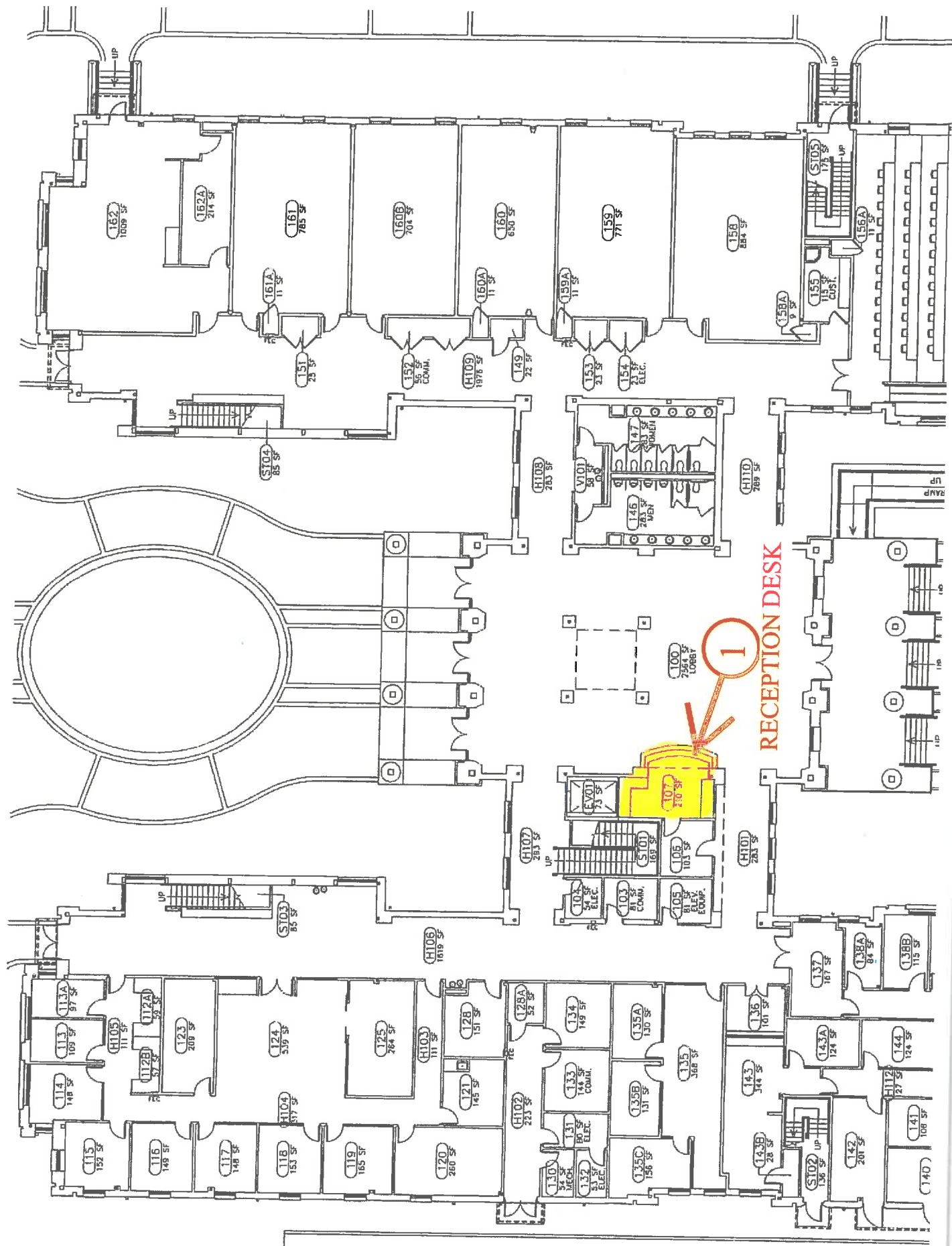

1

RECEPTION DESK

100
2584 SF
LOBBY

101
210 SF

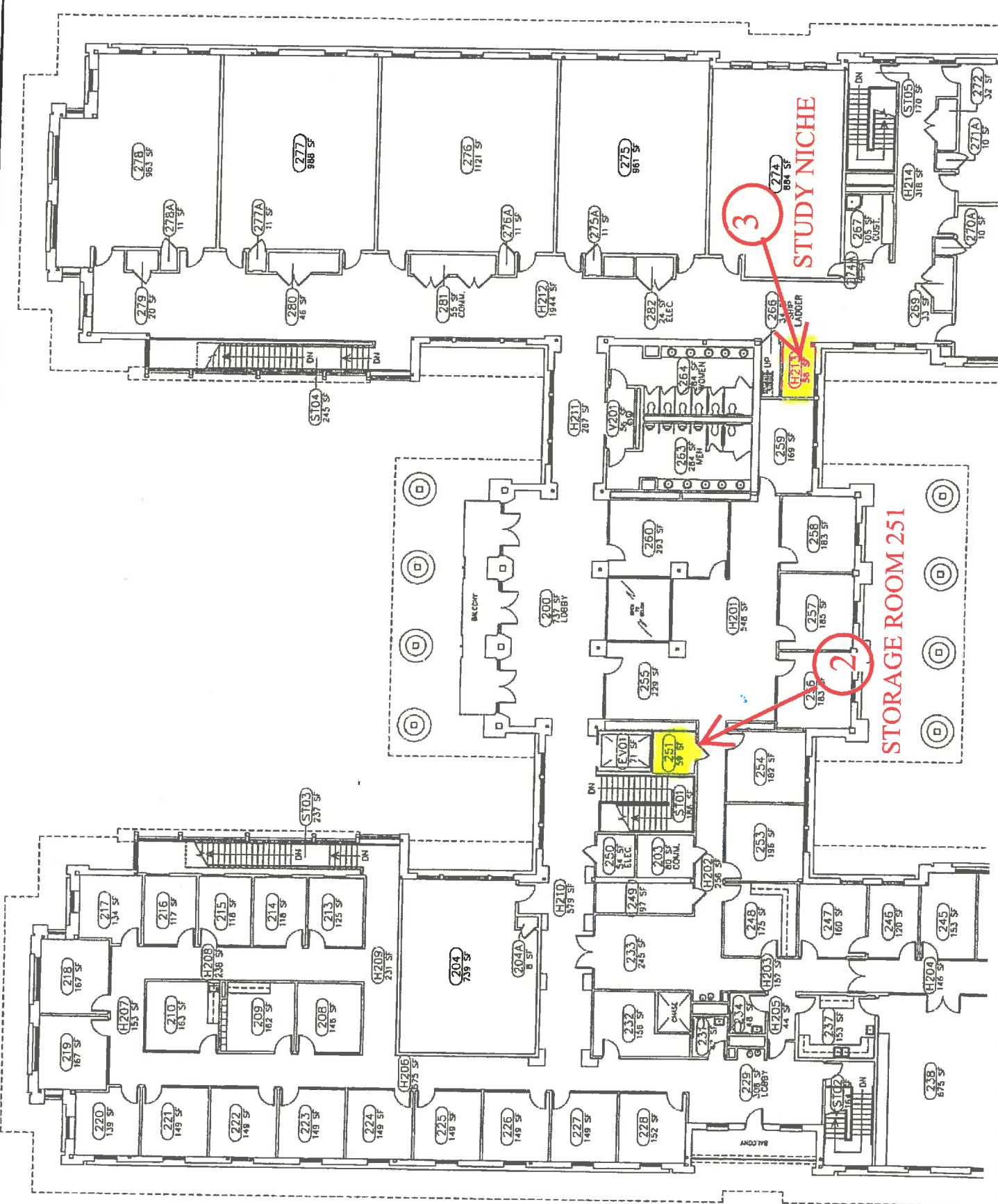

STORAGE ROOM 251

STUDY NICHE

3

2

277A
864 SF

251
59 SF

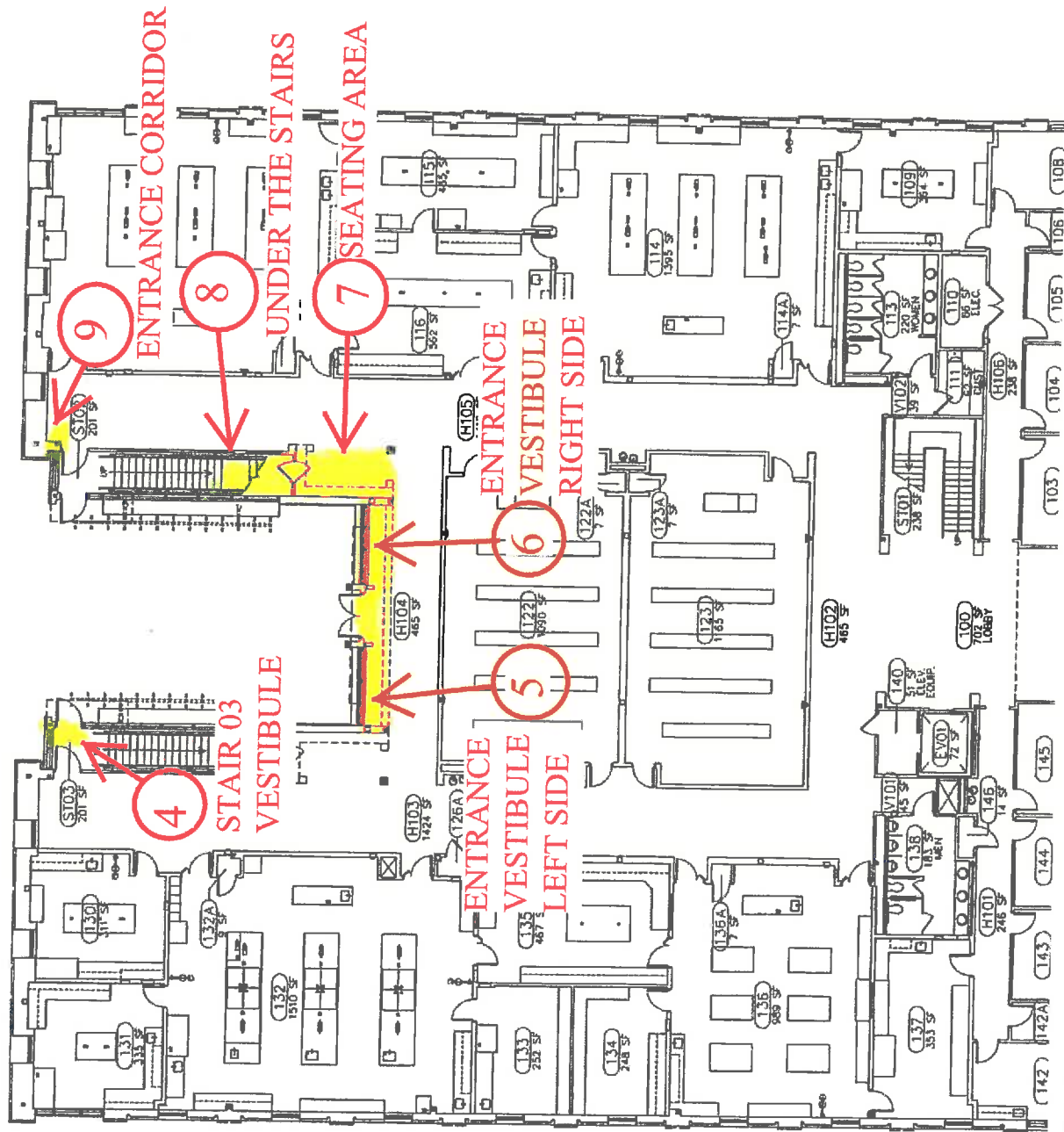

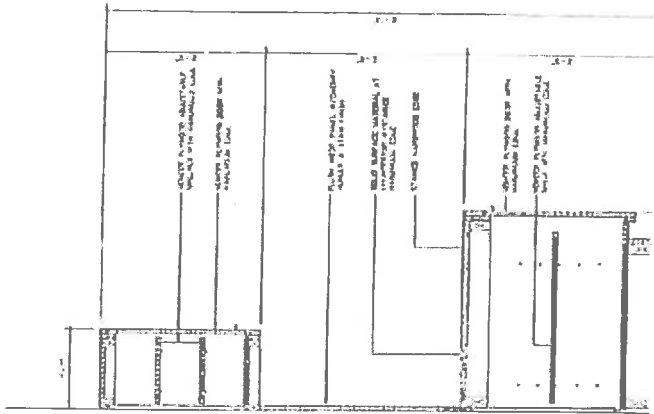

**PLASTIC LAMINATE
 COUNTERTOPS
 AND UPPER AND
 LOWER CABINETS**

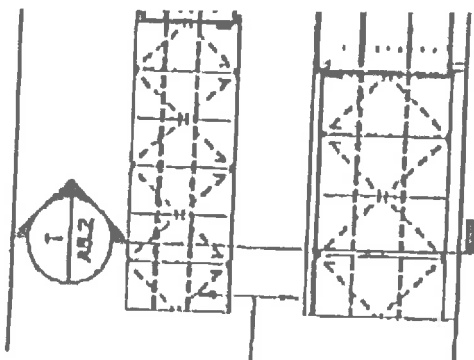

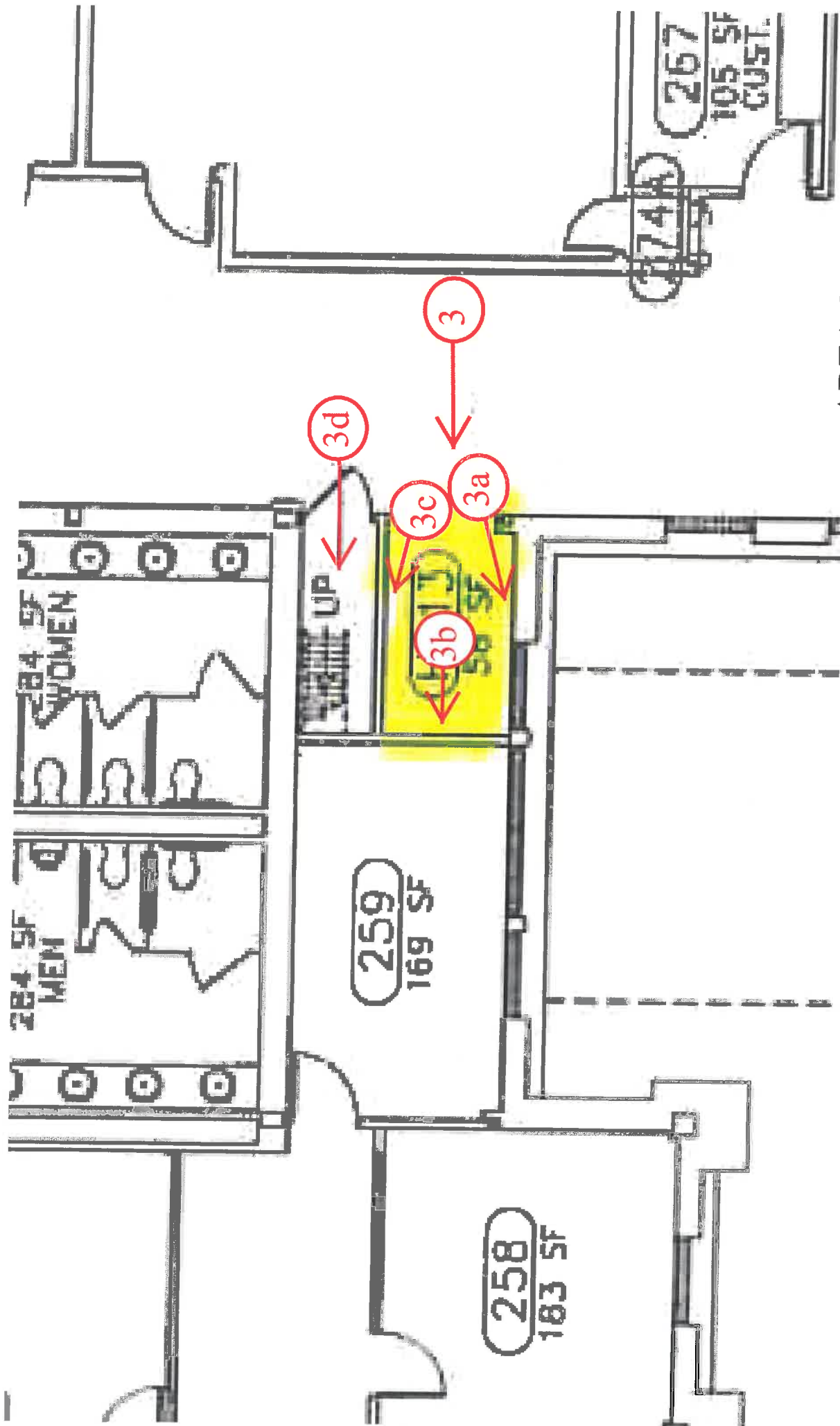

AREA 3
PICTURE
LOCATOR PLAN



REBUILD EXISTING
SOFFIT AND DOOR
FRAMED OPENING



REMOVE AND
REPLACE ALL
WET, DAMAGED
OR MISSING
INSULATION

REPLACE MISSING GYP
BOARD AND PAINT TO
MATCH EXISTING FINISHES

PICTURE # 3

PICTURE # 3a

AREA - 3 STUDY NICHE



**REPLACE MISSING
AND DAMAGED
CEILING TILES**

**REMOVE AND REPLACE ALL WET,
DAMAGED OR MISSING INSULATION**

**REPLACE MISSING GYP
BOARD AND PAINT TO
MATCH EXISTING FINISHES**

**PROVIDE CARPET TILE AND FLOOR
MOLDING TO MATCH EXISTING**

PICTURE # 3b

PICTURE # 3c



REPLACE WET, DAMAGED OR MISSING GYP BOARD. PAINT TO MATCH ADJACENT FINISHES

REMOVE WET, DAMAGED OR MISSING INSULATION LOCATED BEHIND THE STAIR.

(PICTURE OMITTED)

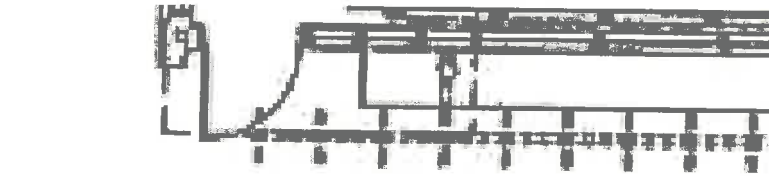

AREA 4
PICTURE LOCATOR
PLAN

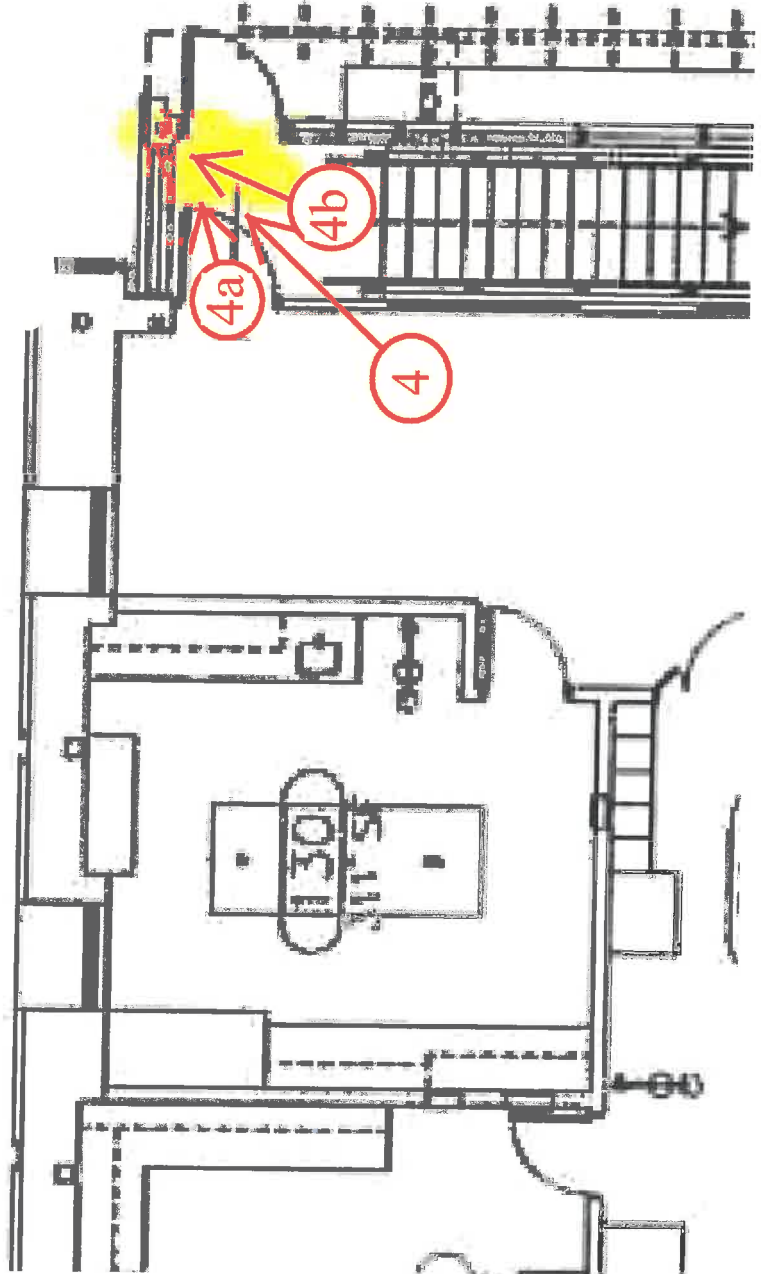



PICTURE # 4a

PICTURE # 4

AREA # 4 STAIR O3 VESTIBULE



(PICTURE OMITTED)

PICTURE # 4b

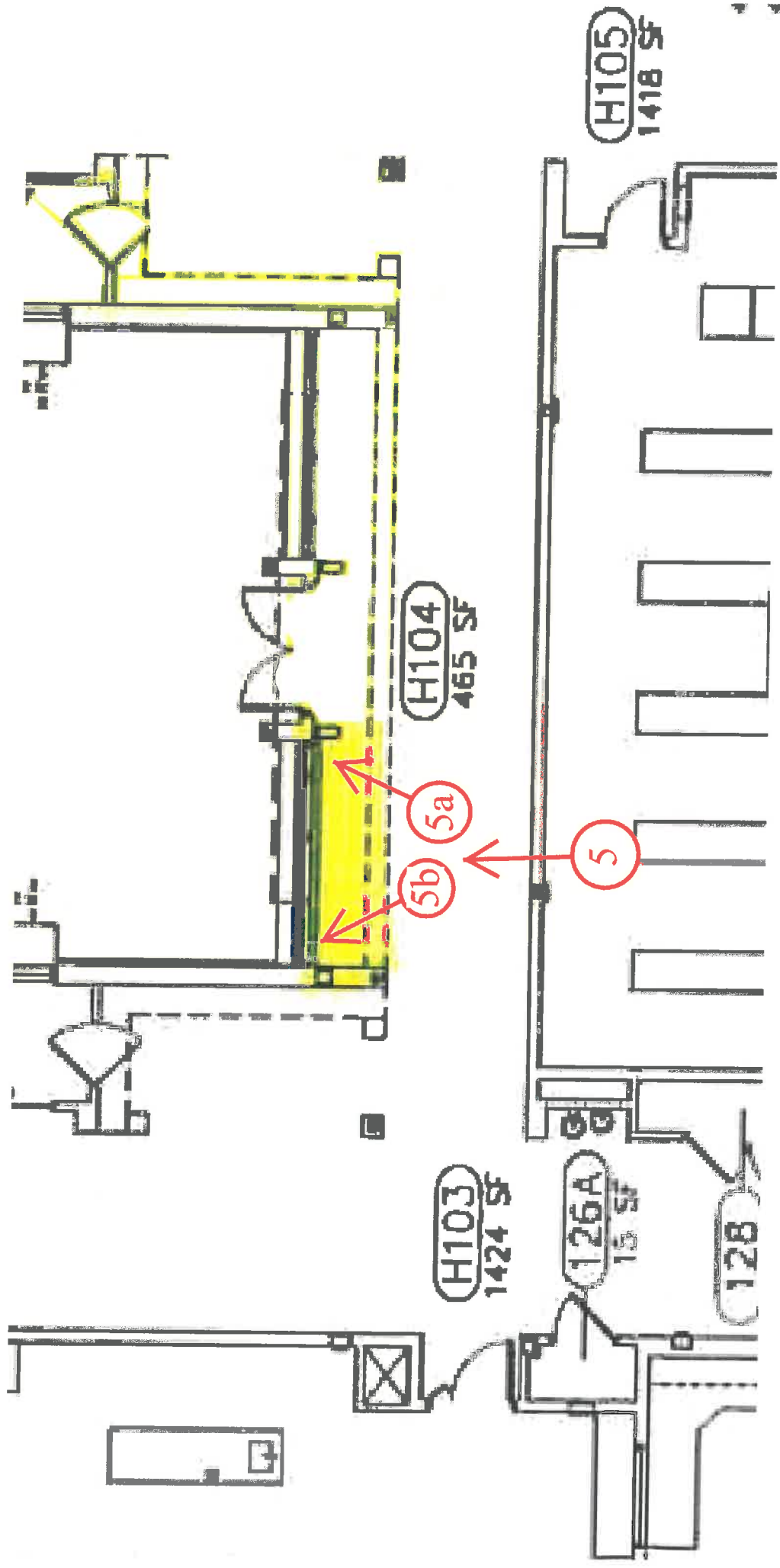

AREA 5
PICTURE LOCATOR
PLAN



PICTURE # 5

AREA # 5 ENTRANCE VESTIBULE LEFT SIDE



REPAIR AND REPAINT
DAMAGED GYP BOARD TO
MATCH EXISTING FINISHES

PICTURE # 5b



REPAIR AND REPAINT
DAMAGED GYP BOARD TO
MATCH EXISTING FINISHES

PICTURE # 5a

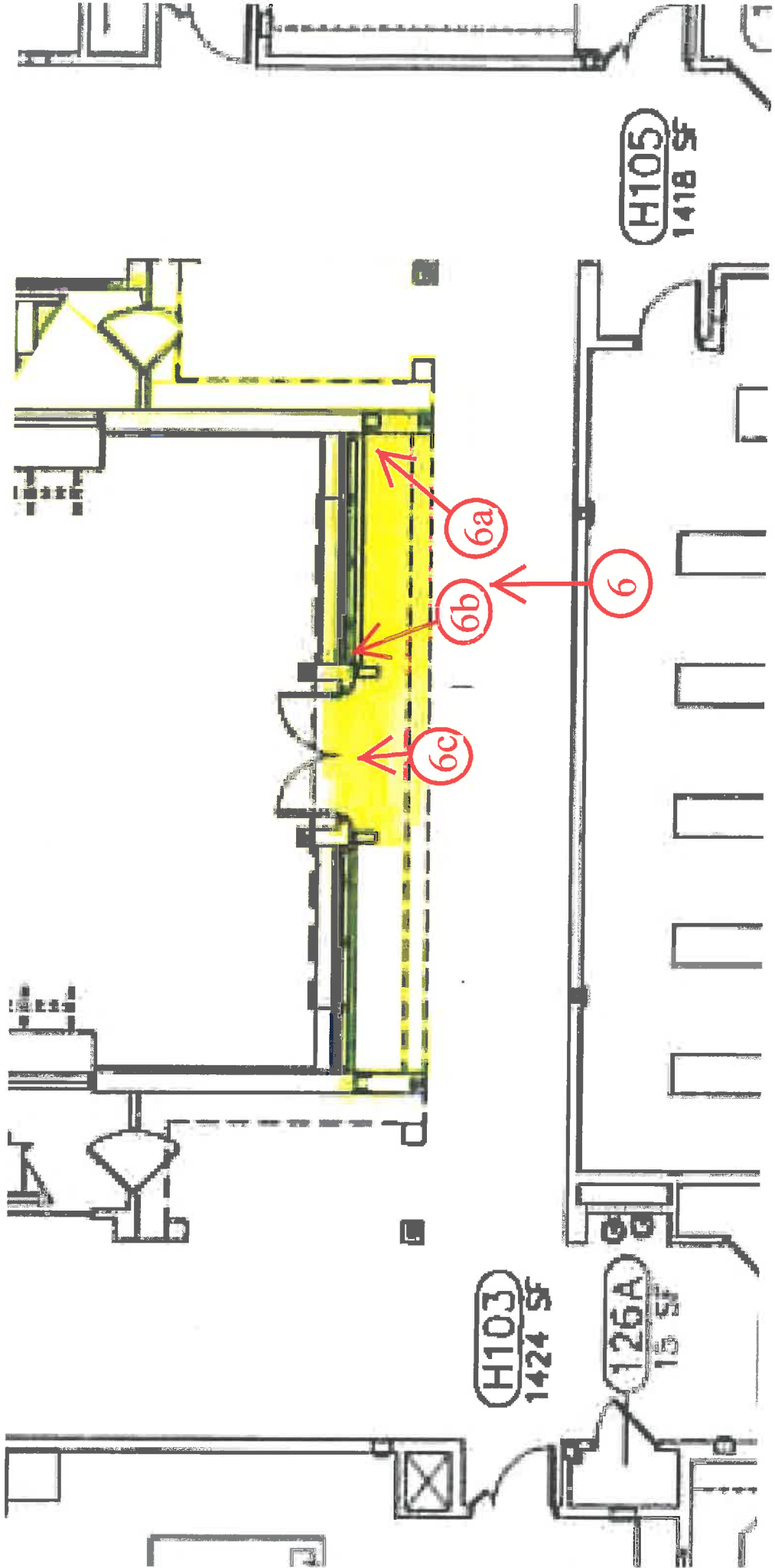

AREA 6
PICTURE LOCATOR
PLAN



REPLACE MISSING WALL
PANEL AND FLOOR MOLDING

CLEAN AND DISINFECT THE WALL CAVITY. REPLACE
FLOOR MOLDING AND GYP BOARD. PAINT TO MATCH
EXISTING ADJACENT SURFACES

PICTURE # 6

AREA # 6 ENTRANCE VESTIBULE RIGHT SIDE

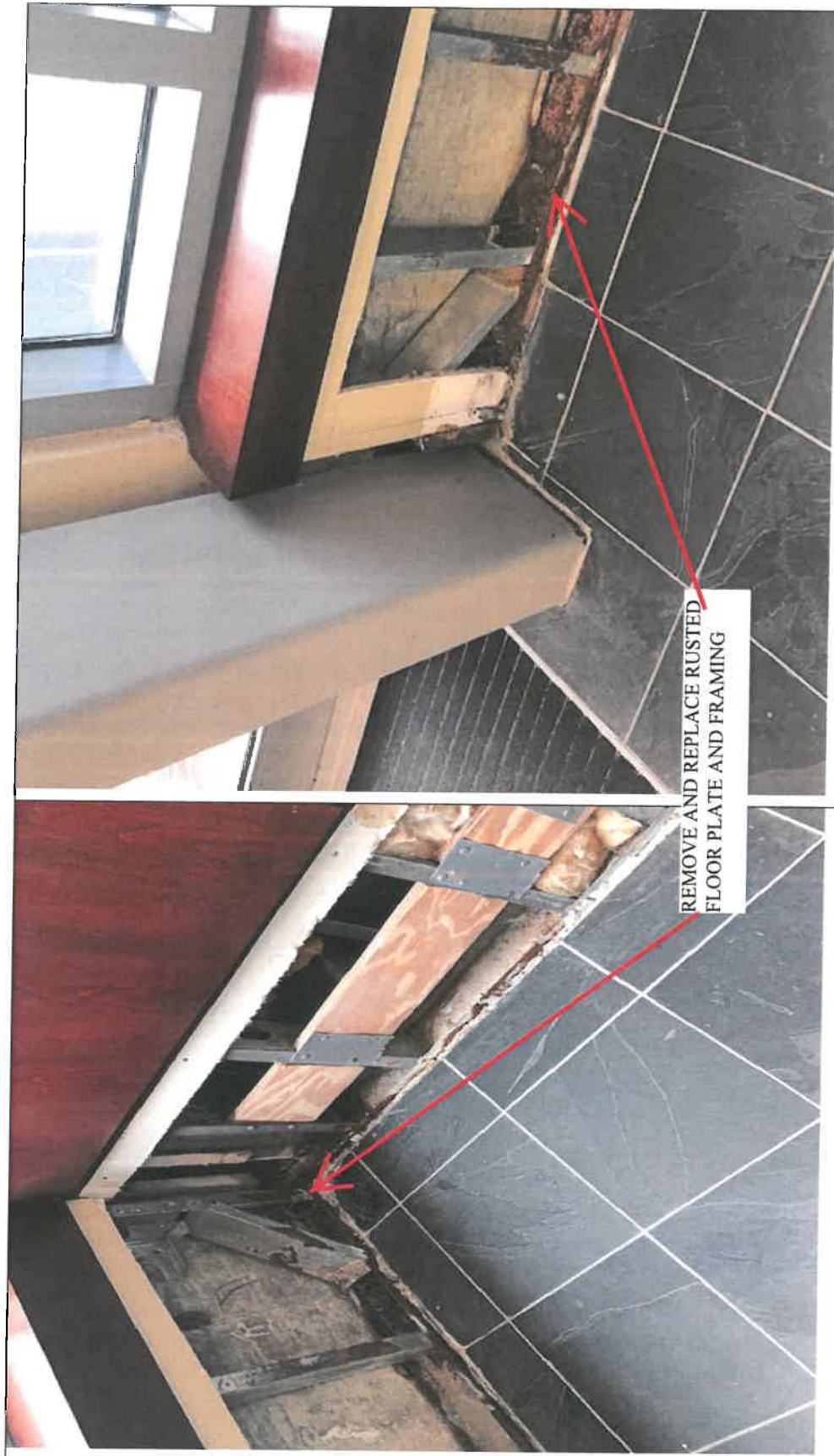

PICTURE # 6a

PICTURE # 6b



REMOVE, REPLACE AND
REPAINT GYP BOARD
AROUND DOOR. FINISHES
TO MATCH EXISTING
ADJACENT FINISHES

(PICTURE OMITTED)

PICTURE # 6c

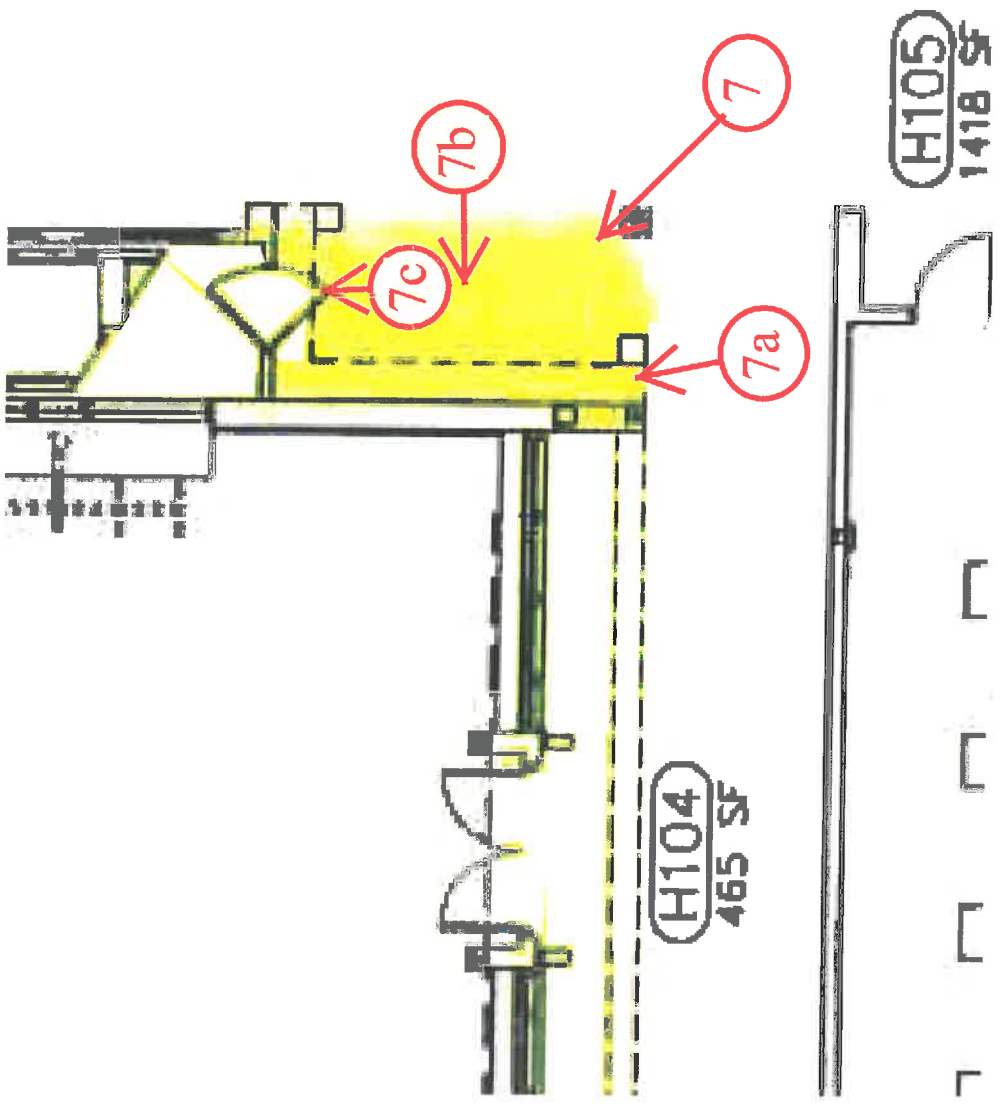
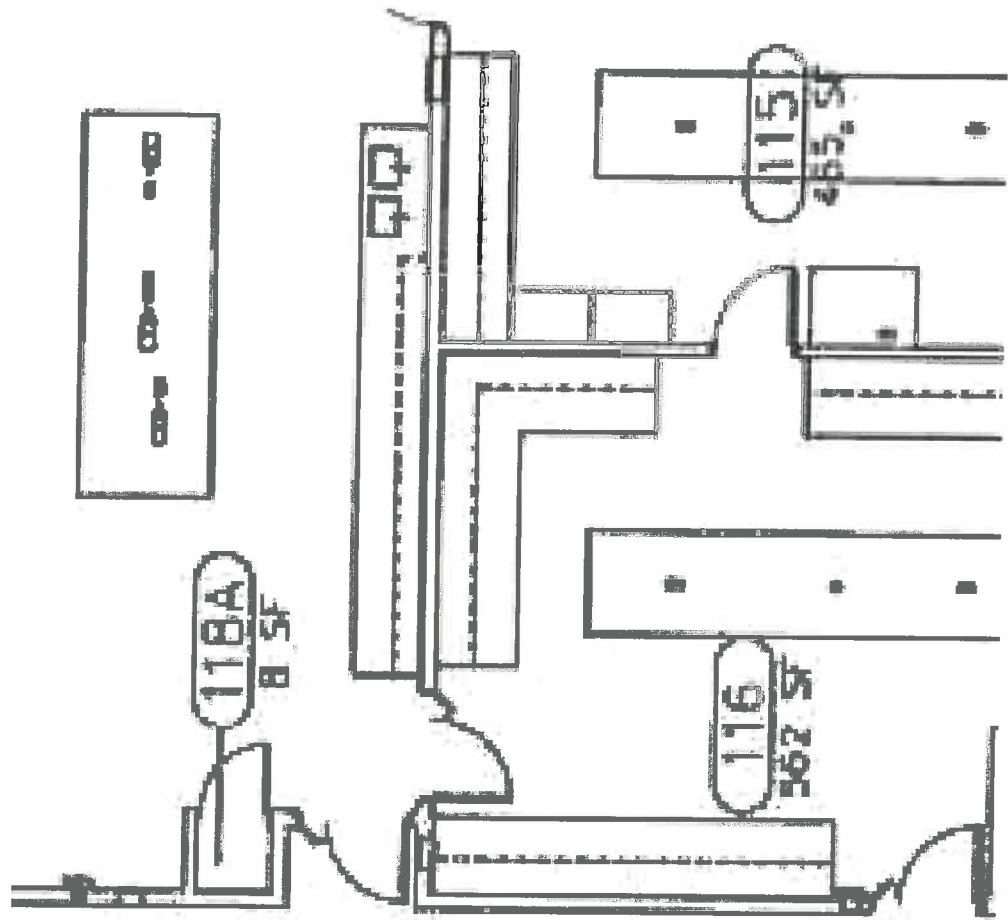



PICTURE # 7

AREA 7 - SEATING AREA



PICTURE 7a



REPLACE MISSING WALL PANEL
AND FLOOR MOLDING. FINISH
TO MATCH ADJACENT FINISHES

CLEAN FLOOR AND
PROVIDE NEW CARPET
TILE TO MATCH EXISTING
CARPET

PICTURE # 7b



PICTURE # 7C

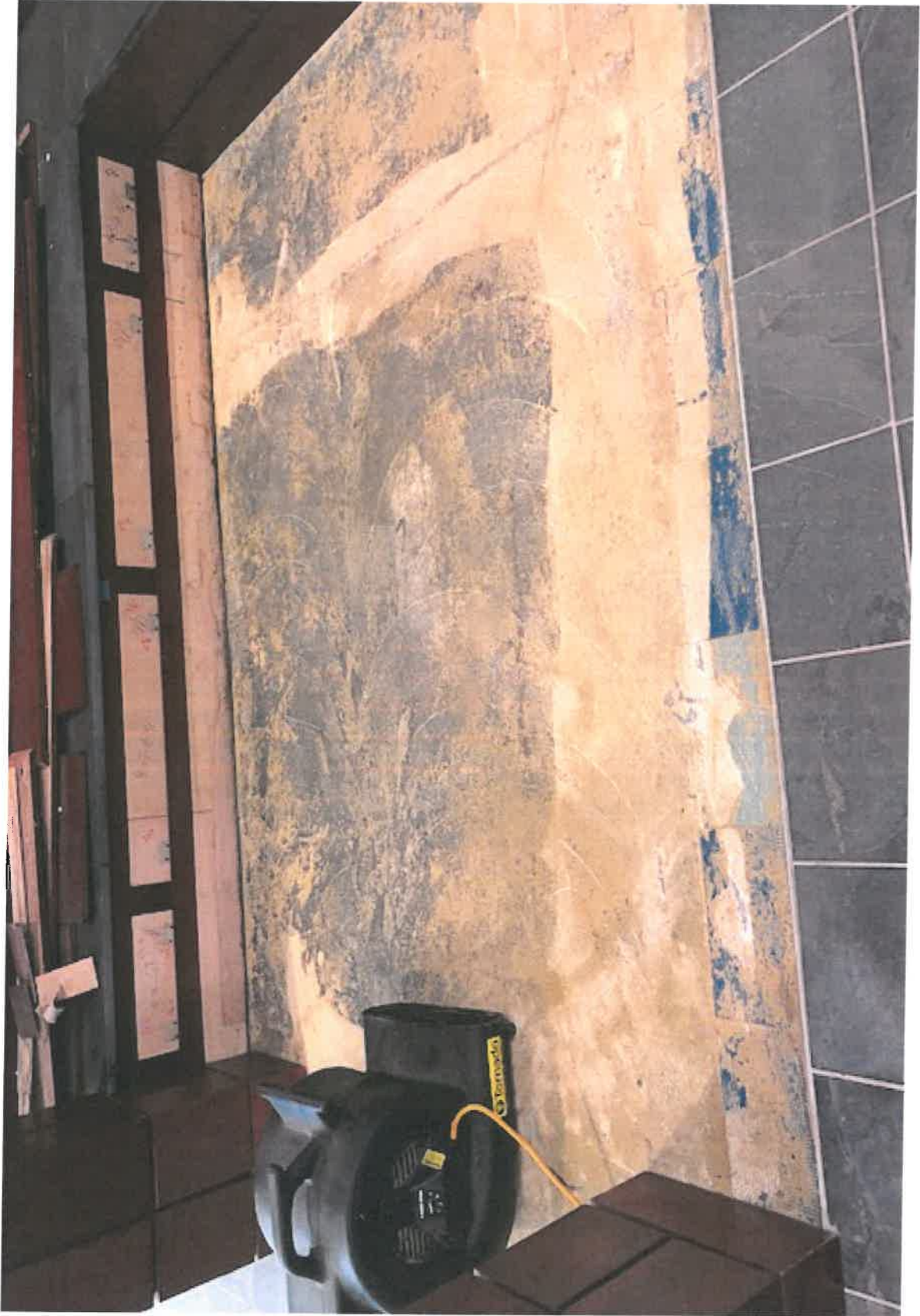

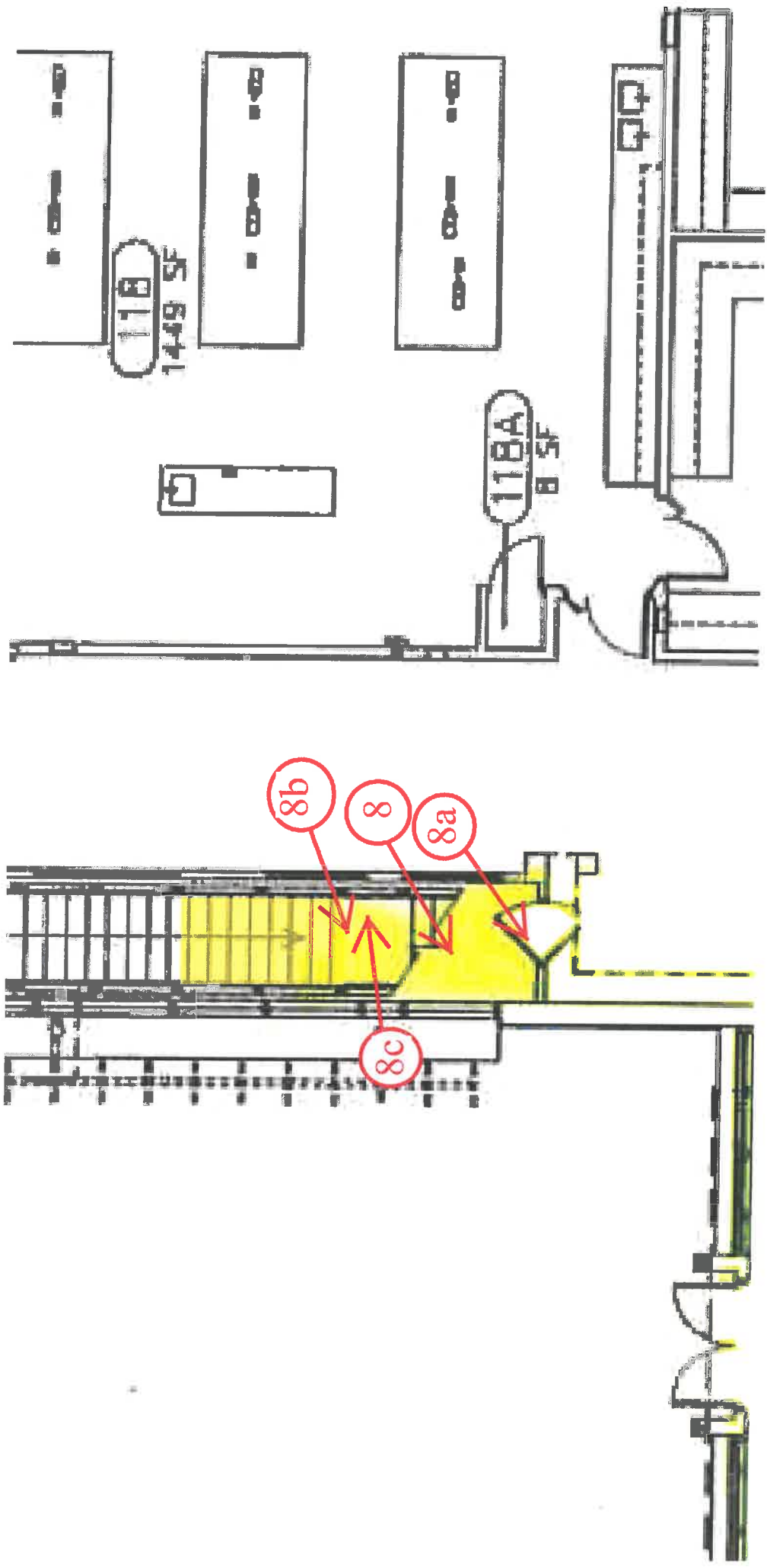

AREA 8
PICTURE LOCATOR
PLAN

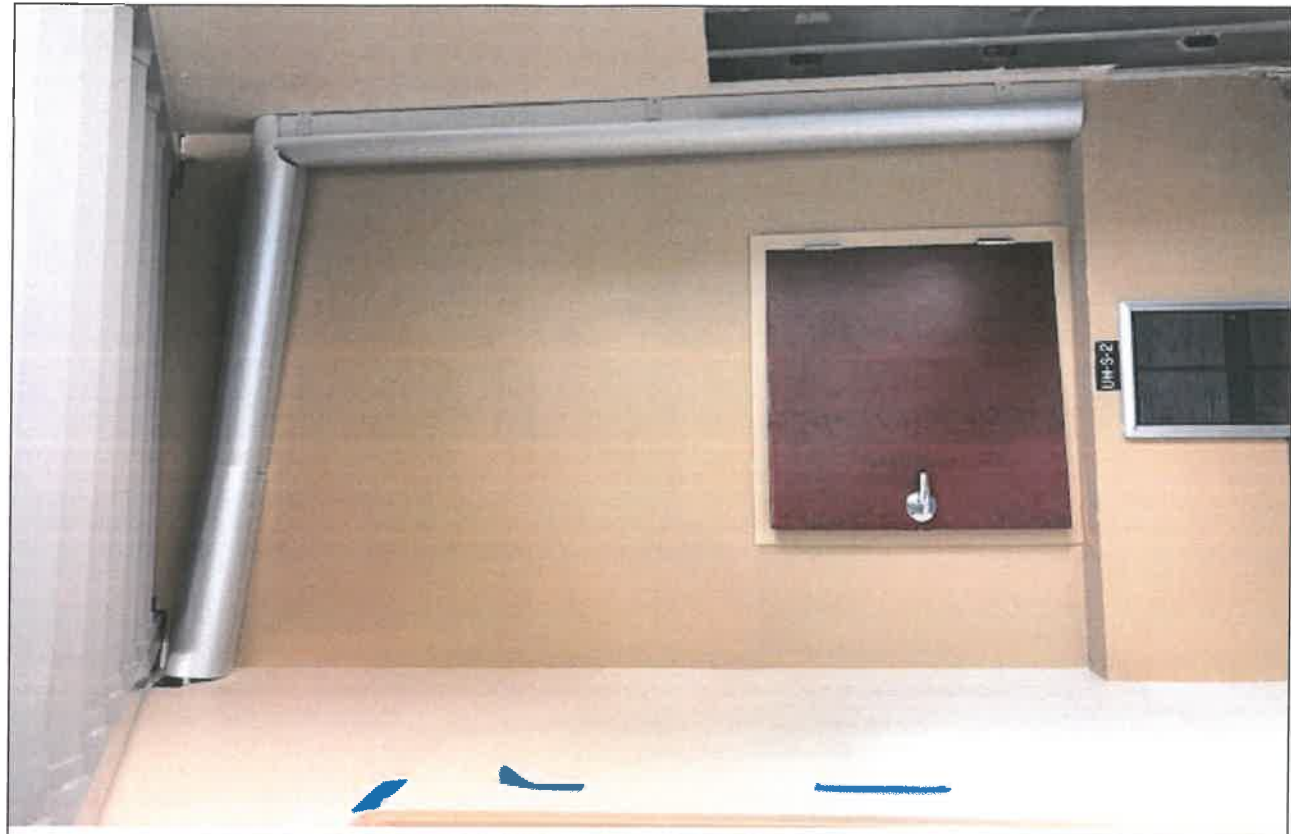

PICTURE # 8a



CLEAN AND DISINFECT THE WALL
CAVITY . REPLACE FLOOR MOLDING AND
GYP BOARD. PAINT TO MATCH EXISTING
ADJACENT SURFACES

PICTURE # 8
AREA # 8 UNDER STAIRS



CLEAN AND DISINFECT THE WALL CAVITY. REPLACE FLOOR MOLDING AND GYP BOARD. PAINT TO MATCH EXISTING ADJACENT SURFACES

PICTURE # 8b



REMOVE TAPE AND ADHESIVE AND REPAIR WALL TO MATCH EXISTING ADJACENT FINISHES

PICTURE # 8c

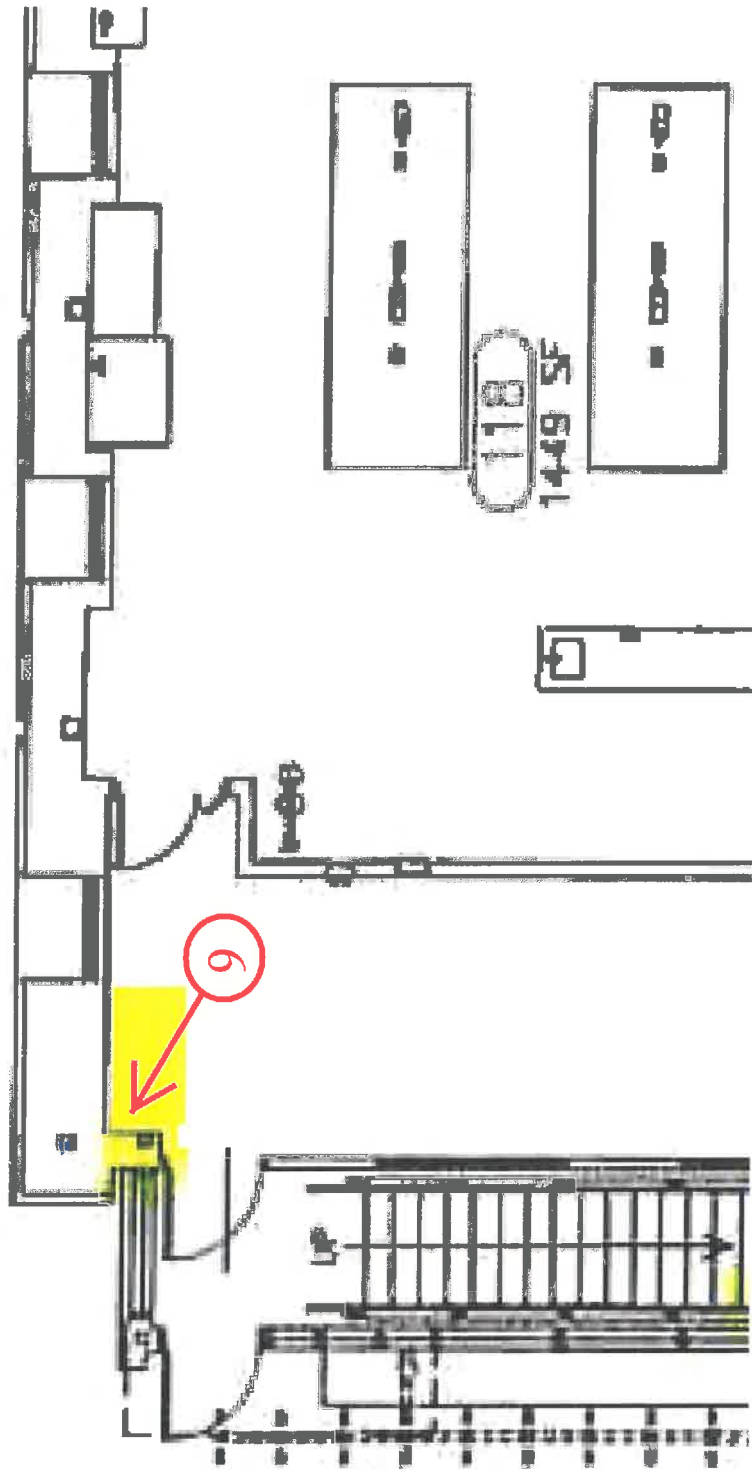

AREA 9
PICTURE LOCATOR
PLAN

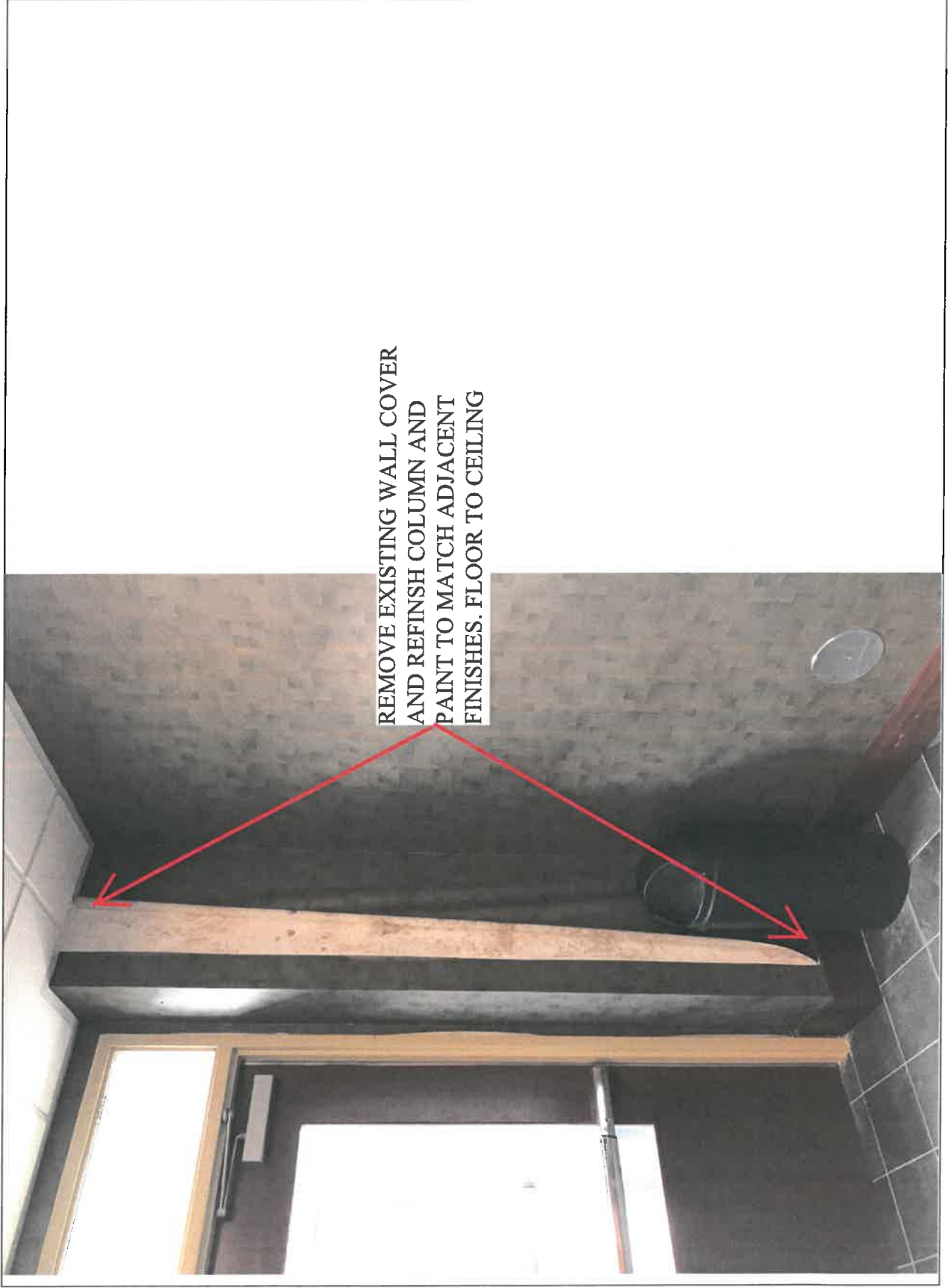

REMOVE EXISTING WALL COVER
AND REFINISH COLUMN AND
PAINT TO MATCH ADJACENT
FINISHES. FLOOR TO CEILING

PICTURE # 9

AREA # 9 ENTRANCE CORRIDIOR